



- **Standard VoIP phone**
- **Vandal resistant handset and cord**
- **Weather proof protection to IP67**
- **Full keypad with memory, 0-9 buttons can be programmed as speed dial button.**
- **“LR” button for last number redial**
- **“R” for flash recall**
- **“M” for muting**
- **Wall mounting (Optional Column mounting), Simple installation**
- **Inductive coupler fitted as standard for hard of hearing**
- **External power supply or PoE (SIP-VoIP)**
- **RJ45 port for VoIP phone**
- **CE, FCC, RoHS, ISO9001 compliant**

The JR100 series telephones are fully contained within a corrosion resistant cast aluminium weatherproof case with a pivoted door providing complete protection against dust and moisture ingress, resulting in a highly reliable product with a long MTBF.

The unique robust handset is manufactured from moulded Bulk Molding Compound and designed specifically to withstand arduous use in all environments, armoured cord to provide additional resistance to vandalism or heavy industrial use.

The JR100 series Weatherproof Telephones are designed for use by the railways, power stations, the armed services and heavy industry which require very reliable telephony under adverse conditions.

SIP-VoIP TECHNICAL SPECIFICATIONS

Adapter Input:

100-240VAC 50~60Hz Output:5V/1A

Port:

WAN:10/100Base- T RJ-45 for LAN, Auto MDIX

LAN:10/100Base- T RJ-45 for PC, Auto MDIX

Power Consumption:

Idle:1.5W/ Active:1.8W

Voice Features

- Support 2 lines SIP, SIP 2.0 (RFC3261)
- Codec: G.711A/u, G.7231 high/low, G.729, G.722,G.726
- Echo cancellation: Support G.168 and hand-free can support 96ms
- Supports full duplex.
- SIP support SIP domain,SIP authentication(none, basic,MD5),DNS name of server, peer to peer
- SIP support 2 servers, user can through each server to calling in and out

Network Features

- WAN/LAN: support Bridge mode
- Support PPPoE for xDSL
- support VLAN
- Support Stun penetration
- Support DHCP get IP on WAN port

TECHNICAL SPECIFICATIONS

Casing Material

Die cast aluminium, epoxy powder coated.

Colors

Yellow, Blue, Red, other colors to special order

Handset Material

Cycoloy with stainless steel spiral cord

Keypad

Rubber Full Keypad

Temperature

Operating: -30°C to +65°C

Storing: -40°C to +75°C

Weather Resistance

IP67

Ringling Tone

Shrill warble tone 85 dBA @ 1 metre typical

Hook switch

Electronic / magnetic with no visible moving parts

M.T.B.F.

Calculated to have an M.T.B.F. in excess of 50,000 hours using

Weight

Up to 6 kg depending on option

DIMENSIONS:

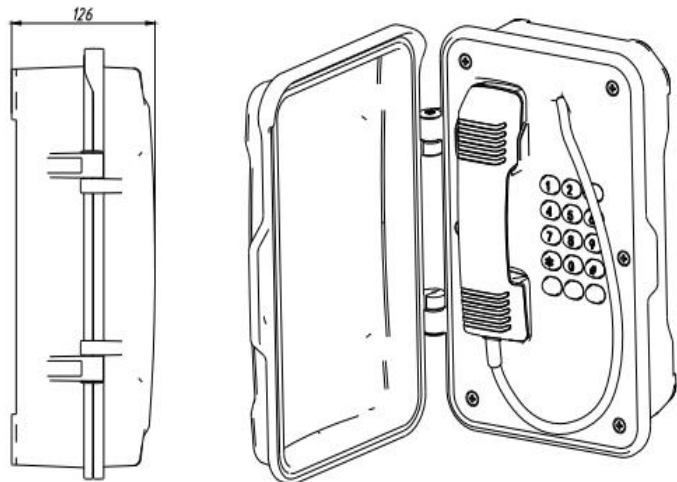
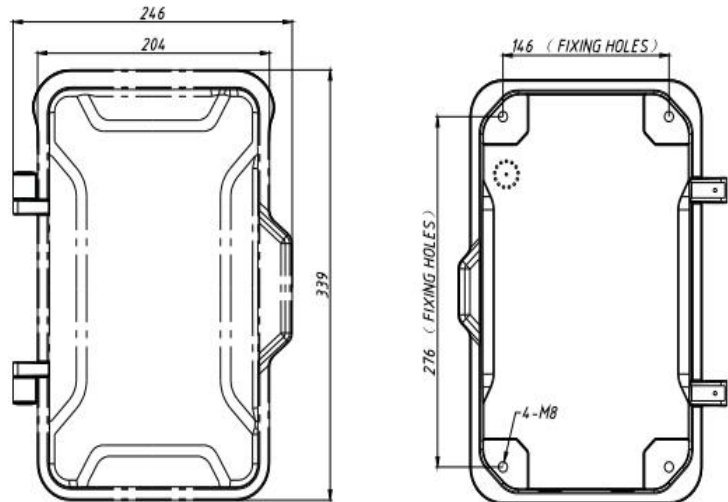

(Measured in mm)

APPROVALS



This mark indicates compliance with the:

Radio & Telecommunications Terminal Equipment Directive

2004/108/EC



This mark indicates compliance with the:

FCC Part 15 Subpart B Class B

PACKAGE

Unit size: 204 *339 *126 (mm)

Carton size: 200*300*440 (mm)

Packaging materials: Pearl cotton, Carton

Gross weight: 7KG

Net weight: 6KG